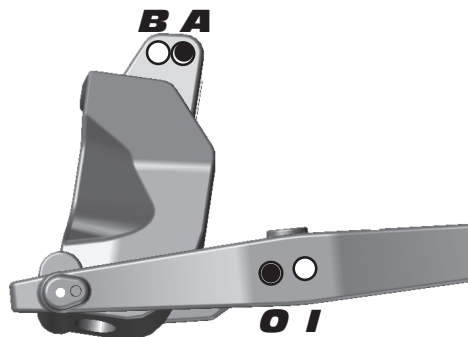
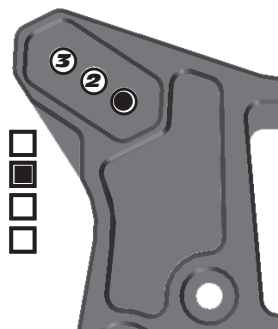

Front Suspension
Steering System:
Swing Rack **Anti Roll Bar:**
Bellcrank Rack
2.2mm Green
2.3mm White
2.4mm Blue
2.5mm Yellow
Bumpsteer
Washers: STD

Camber: 2

Caster: 14

Toe: 2mm out

Ride Height: 28

Upper Hinge Pin Bushing
Front # 2

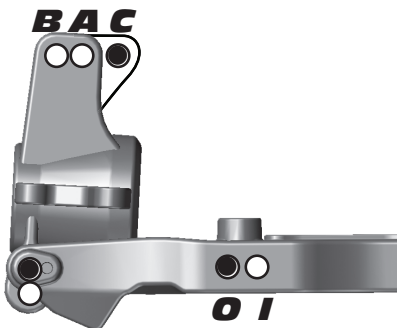
Up **Down**
Rear # 1

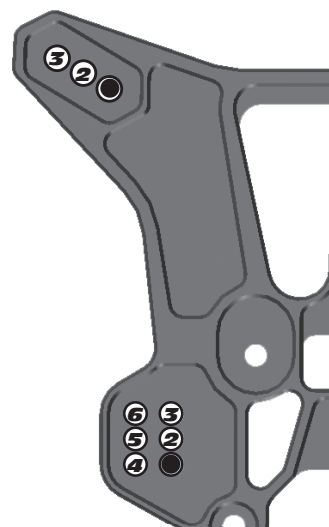
Up **Down**
B-Plate Type
Low **Original**
Kickup Bushing A-Plate
2

Up **Down**
Rear Suspension
RESET
Wheelbase:
Long
Medium
Short
Anti Roll Bar:
2.5mm Green
2.6mm White
2.7mm Blue
2.8mm Yellow
Camber: 2

Hub:
Upper
Lower

Ride Height: 29

Toe Bushing D-Plate
.5

In **Out**
Squat Bushing C-Plate
2

Up **Down**
Front Shocks
Spring: K Blue

Shock Fluid: 32.5

Piston: 1.3 x 8 G

Shock Cap: Bladder

Length: 101

Rebound: Full

Rear Shocks
Spring: K Blue

Shock Fluid: 27.5

Piston: 1.3 x 8 G

Shock Cap: Bladder

Length: 124

Rebound: full

Chassis Braces / Wheel Hex
Chassis Braces:
Pivot
Molded
Aluminum
Wheel Hex:
Standard
Narrow
Chassis Weight
Weight:
Rear Hubs
Rear Hubs:
Standard
CNC FT Alum.
Differentials
Front Diff Fluid: 7

Center Diff Fluid: 5

Rear Diff Fluid: 3

Body / Wing
Body Type: Bulldog PL

Wing Type: PL High Downforce

Gap to Tower (MM): 24

Gearing / Clutch
Spur Gear: 44

Clutch Bell: 17

Clutch Shoes: 1 Alloy, 1 AlloyH, 1 Plastic

Clutch Spring: 1x.9mm 2x 1.0mm

Engine
Engine: VR ST REEDY

Restrictor: TT 6MM **Temp:** 104

Muffler: NR 9901

Glow Plug: RT3 **Fuel:** 30%

Tires
Tire (F/R): Crossbow / Crossbar

Compound (F/R): Blue / Blue

Inserts (F/R): PL Blue / PL Blue

Wheel (F/R): AE / AE

Notes:
Radio / Servos
Radio: **Brake Bias:**
Throttle / Steering Servo: /

Throttle / Brake expo: /

Steering expo:
Dual Rate:
Race and Vehicle Comments
Qualify: 2 **Main:** A **Finish:** 2 **TQ:**
Comments: Elliot used tyre additive in final. Made alot faster.

Track Info
Traction: High Medium Low
Surface: Smooth Bumpy Blue Groove
Soft Dirt Grass Clay Wet
Astroturf Dusty Other: