

Driver: J HOWELLS Track: DERBY Event: SUMMER ROUND

Date: 29TH MAY Track Condition: DAMP A.M. DRY P.M.

Front Suspension

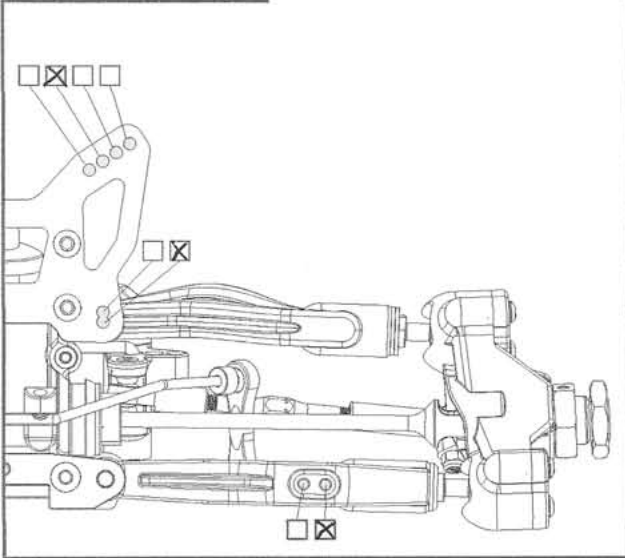

Ackerman

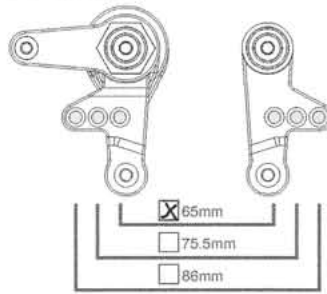

Toe: 1° OUT
 Caster: 2N° SHIM IN FRONT
 Camber: -1
 Anti-roll bar: 2.4 mm
 Ride height: 23 mm
 Droop: 108 mm

Front Shock



2 mm
 Oil: # 30WT
 Piston: 1.5 x 6 mm
 Spring: BLUE
 Length: STD mm

Rear Suspension

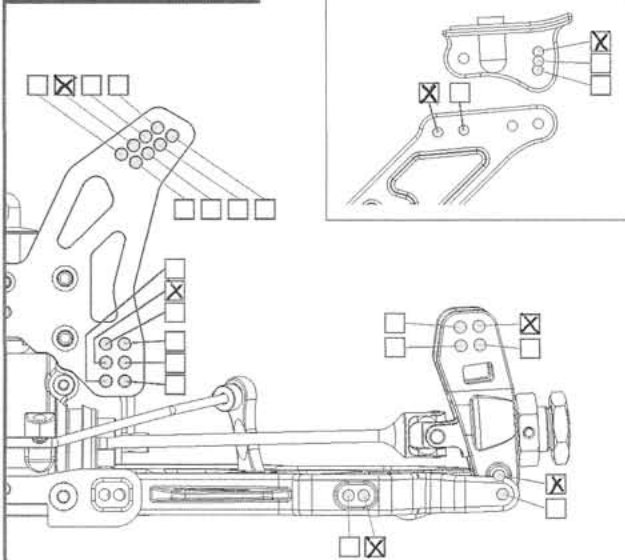

Wheelbase

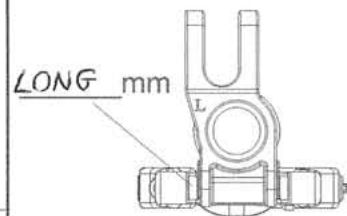

Toe: 3 °
 Camber: -2 °
 Anti-roll bar: 2.6 mm
 Ride height: 24 mm
 Droop: 127 mm
 Anti-squat:

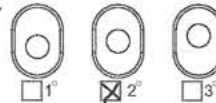

Rear Shock



4 mm
 Oil: # 30WT
 Piston: 5.30 x 6 mm
 Spring: BLUE
 Length: STD mm

Engine

Engine: R.B. B11
 Gasket:
 Glow plug: N°6
 Restrictor: 7MM
 Fuel:
 Muffler: 2045

Tires

	Front	Rear
Brand:	<u>J.C. SABATOOTH</u>	
Compound:	<u>MED</u>	<u>-</u>
Insert:	<u>PROLINE / BLUE</u>	
Wheel:	<u>PROLINE - DISH</u>	

Differentials

Front: # 9 Standard Spider
 Center: # 7 Standard Spider
 Rear: # 4 Standard Spider

Notes

WHITE SPRINGS WORKED BETTER IN THE DAMP. WE ALSO RAN P.S.M. WHEEL HEX PLUS 1MM ON THE REAR

Clutch

Clutch shoes: ALU
 Clutch spring: 3X1mm
 Spur gear: STD
 Pinion gear: 14-T