

Front	Alignment	Rear
5.25	Ride Height	5.75
-1.75	Camber	-1.75
4	Caster	N/A
N/A	Rear Hub Toe	0
0	Toe (Total)	3.5
1mm	Hex Spacing	0.5mm
1mm	Wheelbase	2mm
2B	Steering Link	N/A
3mm	Bumpsteer	N/A

Notes: hard plastic parts

Suspension Geometry		
1A	Shock Position	1B
3	Camber Link Position	3B
black / 0	Outer Ball & Shims	black / 2 mm
B1	FWD Arm Mount	A3
0	FWD Mount Shims	0
B1	RWD Arm Mount	A3
0	RWD Mount Shims	3mm
7	Droop	6
Black	Anti-Roll Bar	Gold

Notes:

Shocks		
55	Oil	50
ae 2	Piston	ae 2
50%	Rebound	50%
Blue	Spring	silver

Notes:

Differentials		
spool	Type	alu
n/a	Setting	-1/4
a	Cam Holder	a
4	Belt Tension Number	6

Notes:

Tires		
sweep 32	Tire	control tyre!
pre glue	Tire Diameter	
jack the grip!	Insert & Wheel	
	Additive & Amount	

Notes: rear 20mins, front 10 mins 1/4 tyre

Chassis: ITF  
 Top Plate: ITF

Notes: O-rings on fwd 2 of the rear top deck screws

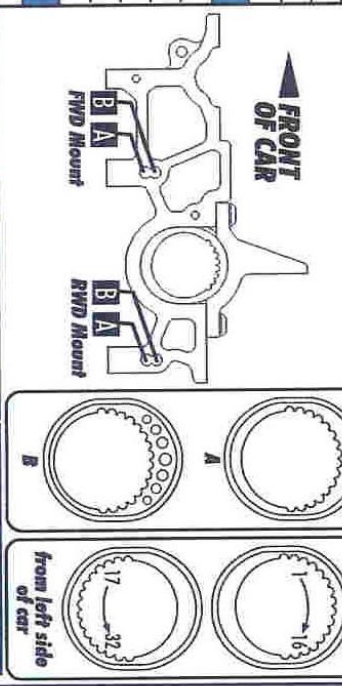
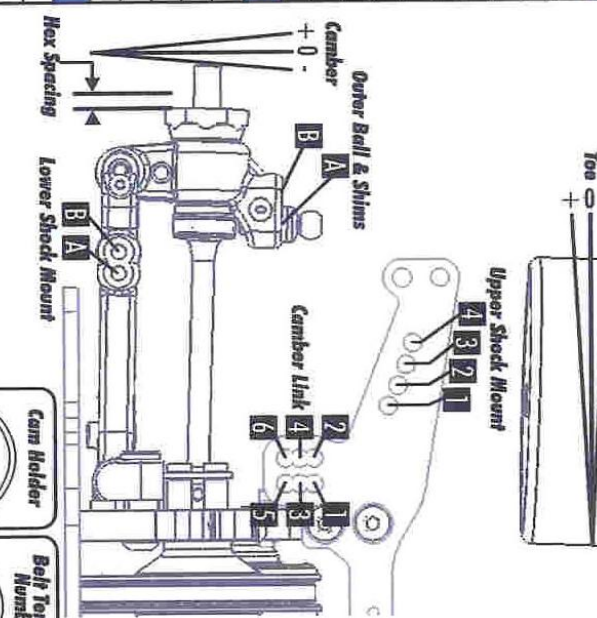
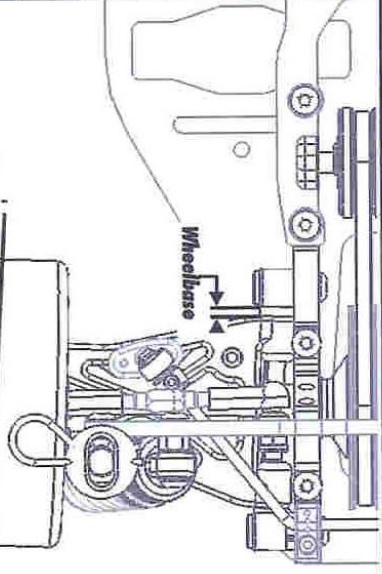

Body & Wing		Battery	
Protaform light mazda 6		Ready! BA6 VMX	

Transmitter	
Turning Circle:	88%
Steering Expo:	-30
Brake F.P.:	-20
Throttle Expo:	+15

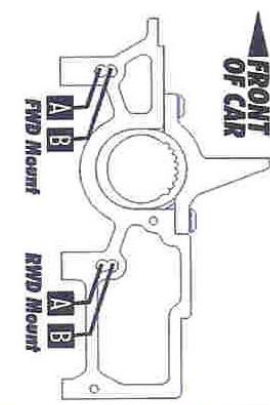

Motor	Gear	Notes
NOVAK 13.5	100 / 41	Novak fitted heat sink on motor